



Short or long

The GURA Mini Belt Conveyor of Series 30350 and 30360 is designed to convey goods up to a max. load of 5 daN/m when space is a problem. It can be used for horizontal transport as stand-alone application or within complete conveying systems in different industrial areas.

As an example: The Mini Belt Conveyor has a very low overall height of only 35 mm and a serial oil and grease resistant PU belt. It is best suited for transporting the output of automatic punching and screw cutting machines and with an additional hopper unit can be used to fill vibrating, sorting and input systems.

Ancillary equipment: guide rails, stainless steel hopper with different capacities, supports, protective motor switch, frequency control to adjust conveying speed,

indexed control device, light barrier control, reverse control and a variety of special belts, for example for applications in the food industry.



GURA Mini Belt Conveyor

- Belt widths (NB) [mm]: 60, 85, 135
- Lengths [mm]: 300 - 5000
- Customized lengths and widths on request
- Capacity: 3 - 5 [daN/m]
- PU belt: oil and grease resistant
- Return pulleys: 22 mm
- Drive pulley: 32 mm
- Gear motor: Durable and maintenance-free, 230 / 400 volts, 50Hz
- Frame: anodized aluminium industrial profile
- Belt glides over the stainless steel sheet
- Belt speed (v) up to: series 30350 max. 15m/min; series 30360 max. 60m/min, frequency control (three phase A.C.), control range 1/7

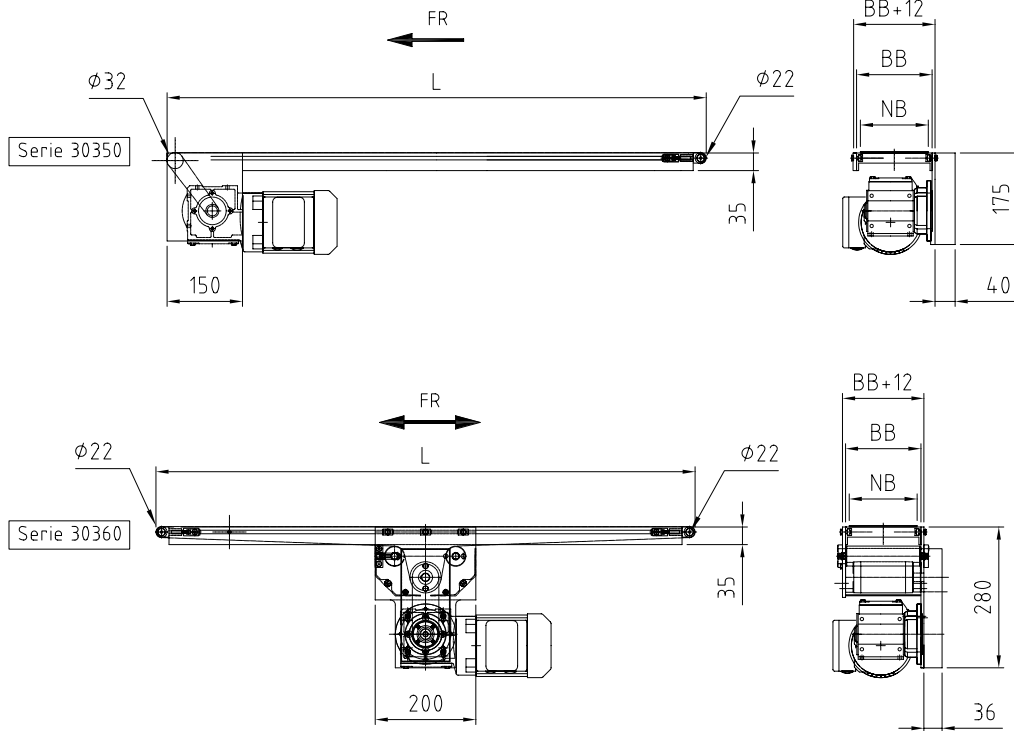

Mini Belt Conveyor

Series	NB [mm]	Roller pitch (A-A) [mm]	Drive*	v [m/min]	Belt Material	Capacity* [daN]
30350	60, 85, 135	300-5000	230/400V, 50hz	max. 15	PU / PVC	15
30360	60, 85, 135	500-5000	230/400V, 50hz	max. 60	PU / PVC	25

* Benchmarks
 Mandatory values on request.

Ancillary Equipment:

Series	Description
	Single support with base plate, height adjustable up to max. 1200 mm protective motor switch with electric plug and 3 m cable frequency regulation for continuous rpm control guidance: 25, 50, 75 mm high, trough 10-50 mm high

Example order: 30350 – 60 – 2000 = Mini Belt Conveyor, Series 30350

- 30350 = Series-No.
- 60 = Working width (NB) [mm]
- 2000 = Roller pitch (A-A) [mm]